

PRODUCT SPECIFICATION

Model No.: CSDS-56108VM_CSDS-56109VM

Descriptions:
<ul style="list-style-type: none"> ■ 0.56 Inch Single Digit Display ■ CSDS-56108 is Common Anode ■ CSDS-56109 is Common Cathode ■ Emitting Color: Orange ; Yellow Green ■ Standard: -11: Gray face, white segment. -21: Black face, white segment..



CUSTOMER APPROVED SIGNATURES	APPROVED BY	CHECKED BY	PREPARED BY

OPTO PLUS TECHNOLOGIES CO.,LTD
 Address:No.696,Yangming North Rd,
 ShaoXing City,ZheJiang Province, P.R.China.
 Tel :86-575-88623888
 Fax:86-575-88623112

Model No.: CSDS-56108VM CSDS-56109VM

Features -

1. 0.56 inch (14.20mm) digit height.
2. Case mold type.
3. RoHS compliant.
4. Low power consumption.
5. Easy mounting on P.C. board or socket.

Device Selection Guide -

Model No.	Chip	
	Material	Emitting Color
CSDS-5610XVM	AlGaInP	Orange
		Yellow Green

LED Numeric/Alphanumeric Display

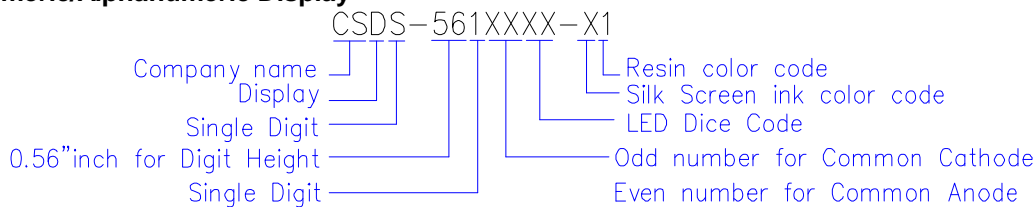

Mechanical Dimensions -

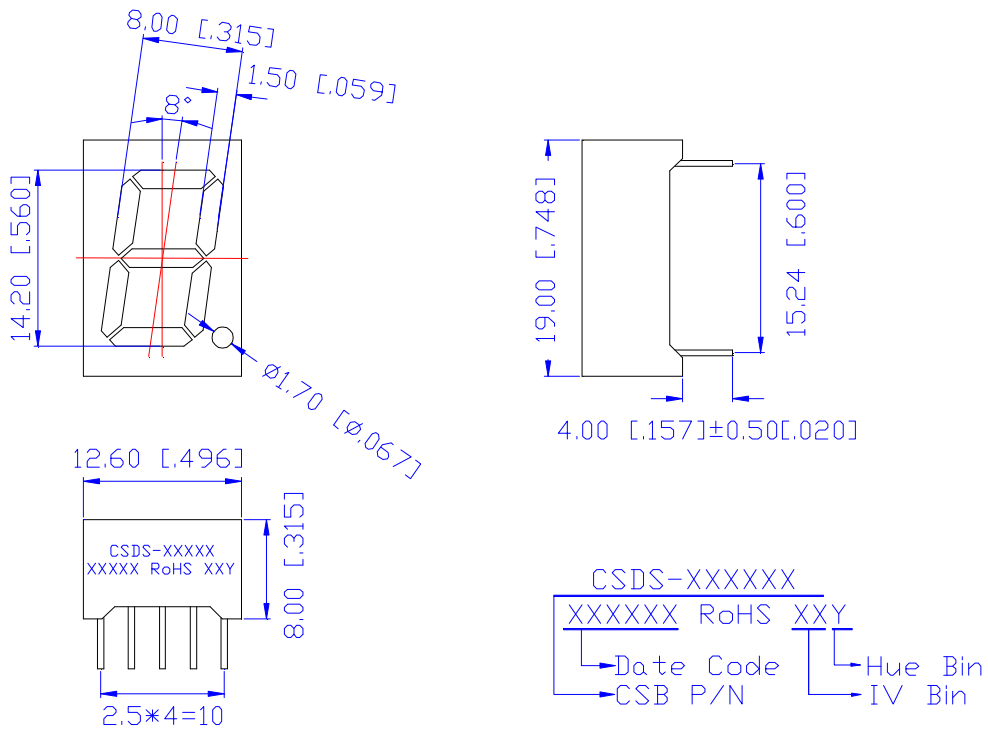

Notes:

1. All pins are $\phi 0.51 [0.020] \pm 0.1 [0.004]$
2. Dimension in millimeter [inch], tolerance is $\pm 0.25 [0.010]$ and angle is $\pm 1^\circ$ unless otherwise noted.
3. Bending \leq Length * 1%.

Model No.: CSDS-56108VM CSDS-56109VM

■ All Light On Segments Feature & Pin Position

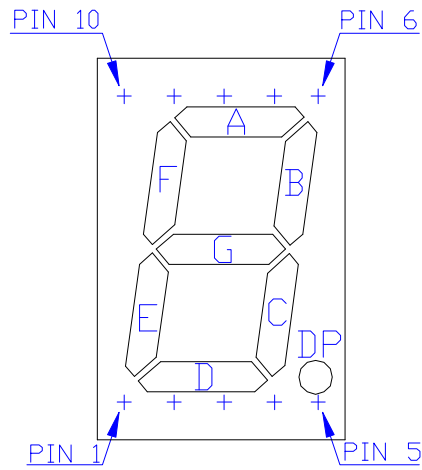

■ Internal Circuit Diagrams -

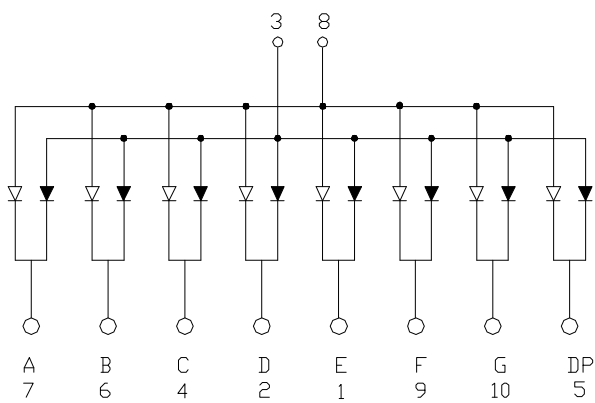

Orange
 Yellow Green

CSDS-56108 is Common Anode

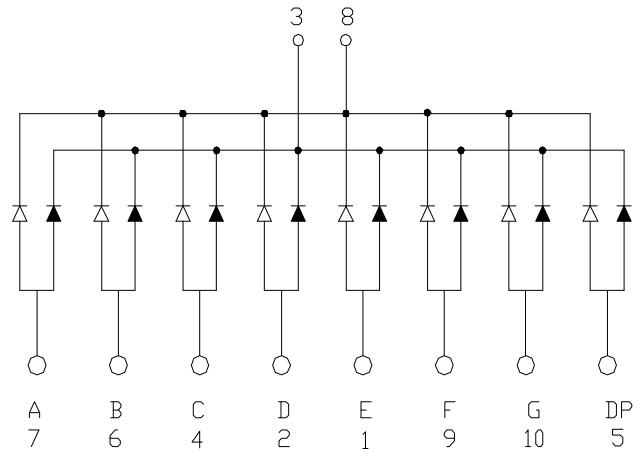

Orange
 Yellow Green

CSDS-56109 is Common Cathode

Model No.: CSDS-56108VM CSDS-56109VM

■ Absolute Maximum Rating -

(Ta=25°C)

Parameter	Symbol	Rating	Unit
Power Dissipation Per Dice	P_{AD}	70	mW
Derating Liner from 25°C per Dice	-	0.33	mA/°C
Continuous Forward Current Per Dice	I_{AF}	25	mA
Peak Current Per Dice(duty cycle 1/10,1KHz)	I_{PF}	90	mA
Reverse Voltage Per Dice	VR	5	V
Operating Temp.	T_{opr}	-35 ~ +85	°C
Storage Temp.	T_{stg}	-35 ~ +85	°C
Hand Soldering Temp.	T_{sol}	350	°C

■ Electro-optical Characteristics -

(Ta=25°C)

Parameter	Symbol	Chip	Min.	Typ.	Max.	Unit	Condition
Luminous Intensity Per Segment	I_v	M	-	11.6	-	mcd	IF=10mA
		V	-	31	-		
Forward Voltage Per Segment	VF	M/V	-	2.0	2.8	V	IF=20mA
Peak Emission Wavelength / Dominant Wavelength	λ_P/λ_d	M	-	572/570	-	nm	IF=10mA
		V	-	632/625	-		
Reverse Current	I_R		-	-	100	μA	VR=5V
Luminous Intensity Matching Ratio	IV-m		-	-	2:1	-	IF=10mA

Typical Electrical / Optical Characteristics Curves -

(Ta = 25°C Unless Otherwise Noted)

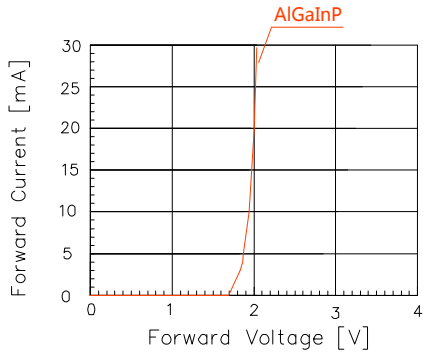

Fig 1. Forward Current vs. Forward Voltage

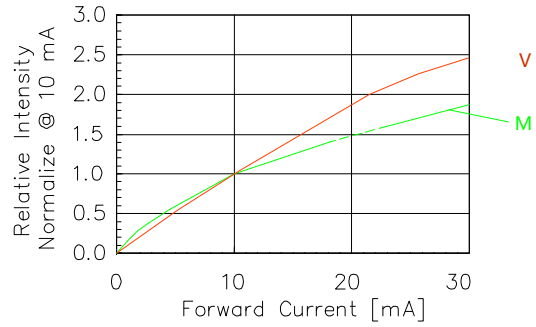

Fig 2. Relative Intensity vs. Forward Current

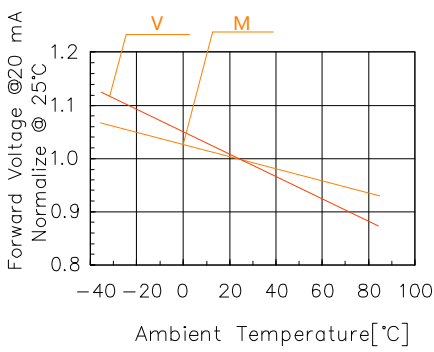

Fig 3. Forward Voltage vs. Temperature

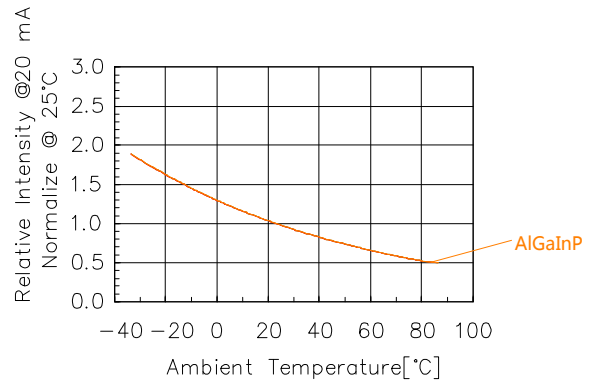

Fig 4. Relative Intensity vs. Temperature

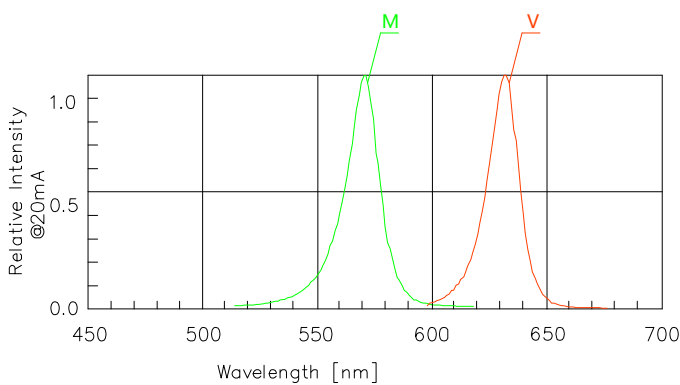

Fig 5. Relative Intensity vs. Wavelength

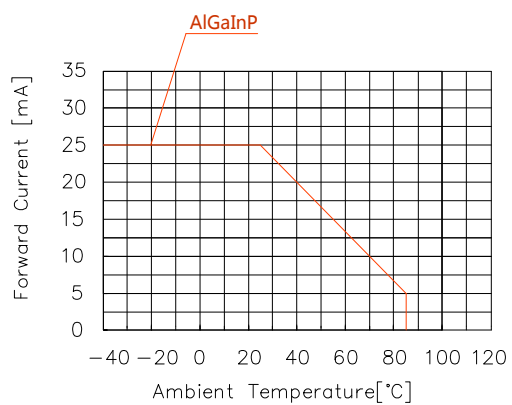

Fig 6. Forward current vs. Temperature

Model No.: CSDS-56108VM CSDS-56109VM

■ Precautions For Use -

1.Wave Soldering Profile

Distance:1.6mm min(From seating plane)

Item	Condition		Note
Preheat	Temperature T1	80 – 120°C	PWB temperature (Soldering side surface)
	Time t1	60 – 180sec	
Solder Dip	Temperature T2	230 – 260°C	Bath temperature
	Time t2	2 – 4sec	Solder tank passage time

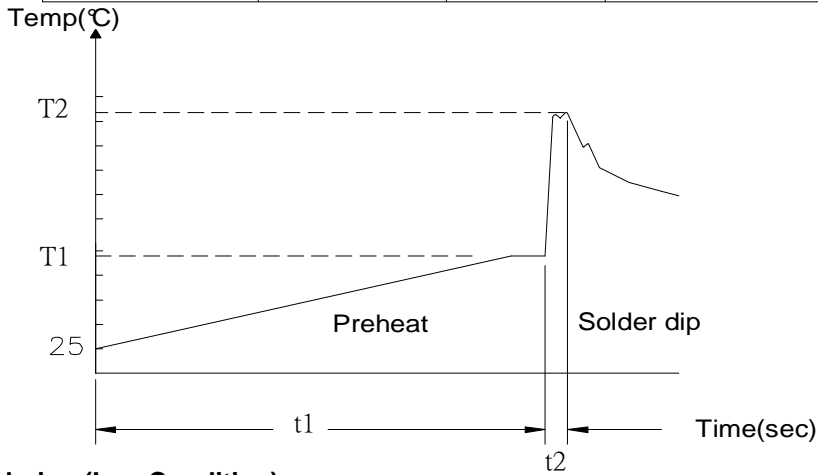

2.Hand Soldering (Iron Condition)

Soldering Iron:30W Max

Temperature 350°C Max

Soldering Time:3 Seconds Max(One Time)

Distance:1.6mm min(From seating plane)