

# PRODUCT SPECIFICATION

**Model No.: CSDT-36300 CSDT-36301**

Descriptions:
<ul style="list-style-type: none"> <li>■ 0.36 Inch Triple Digit Display</li> <li>■ CSDT-36300 is Common Anode</li> <li>■ CSDT-36301 is Common Cathode</li> <li>■ Emitting Color: Pure Green; Yellow Green; Yellow; Amber; Orange; Red; Deep Red</li> <li>■ Standard: -11: Gray face, white segment. -21: Black face, white segment.</li> </ul>



CUSTOMER APPROVED SIGNATURES	APPROVED BY	CHECKED BY	PREPARED BY

**OPTO PLUS TECHNOLOGIES CO.,LTD**  
 Address:No.696,Yangming North Rd,  
 ShaoXing City,ZheJiang Province, P.R.China.  
 Tel :86-575-88623888  
 Fax:86-575-88623112

**Model No.: CSDT-36300 CSDT-36301**
**■ Features -**

1. 0.36 inch (9.2mm) digit height.
2. Case mold type.
3. RoHS compliant.
4. Low power consumption.
5. Easy mounting on P.C. board or socket.

**■ Device Selection Guide -**

Model No.	Chip	
	Material	Emitting Color
CSDT-3630x2	InGaN	Pure Green
CSDT-3630xM	AlGaInP	Yellow Green
CSDT-3630xT		Yellow
CSDT-3630xA		Amber
CSDT-3630xV		Orange
CSDT-3630xL		Red
CSDT-3630xU		Deep Red

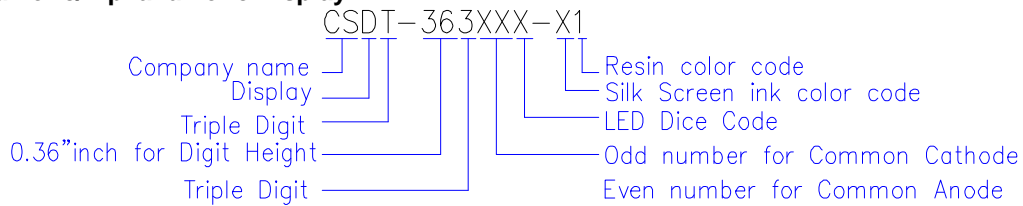
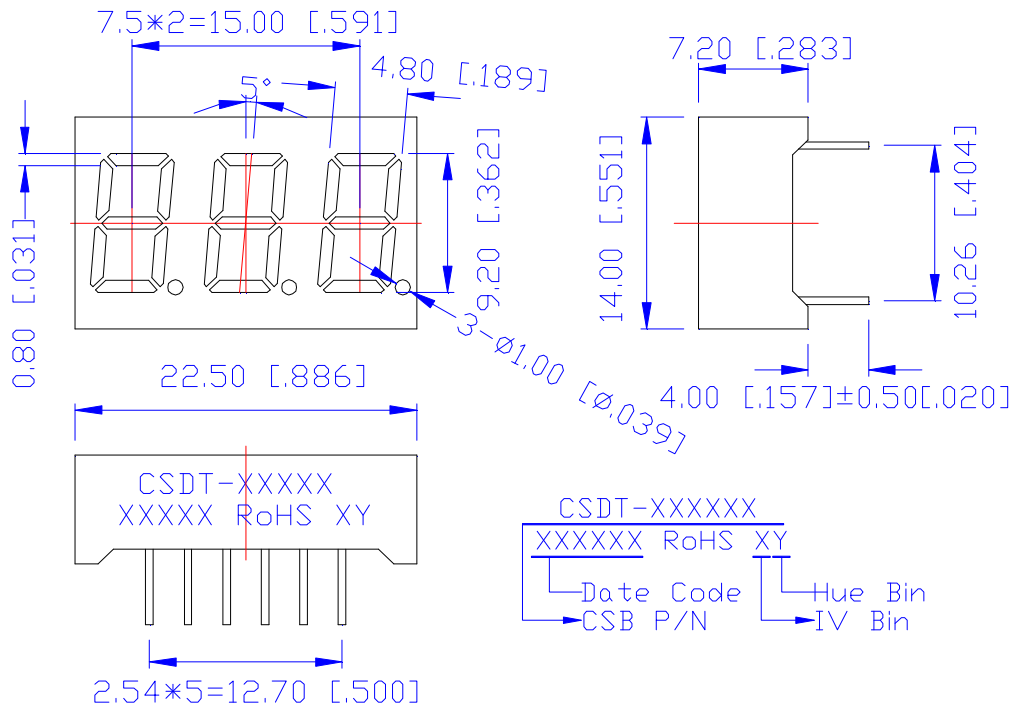
**■ LED Numeric/Alphanumeric Display**

**■ Mechanical Dimensions -**

**Notes:**

1. All pins are ∅0.51[0.020]±0.1[0.004]
2. Dimension in millimeter [inch], tolerance is ±0.25 [0.010] and angle is ±1° unless otherwise noted.
3. Bending ≤ Length\*1%.

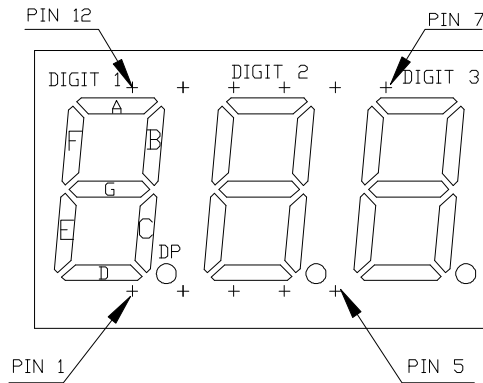
**Model No.: CSDT-36300 CSDT-36301**

**■ All Light On Segments Feature & Pin Position**



**■ Internal Circuit Diagrams -**

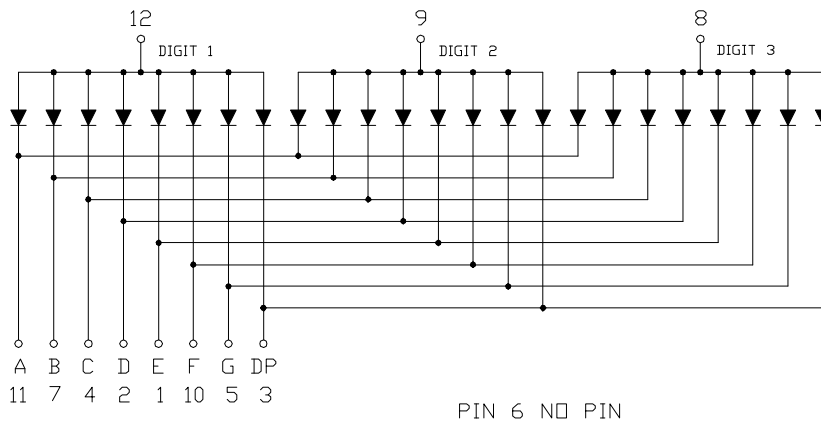

CSDT-36300 is Common Anode

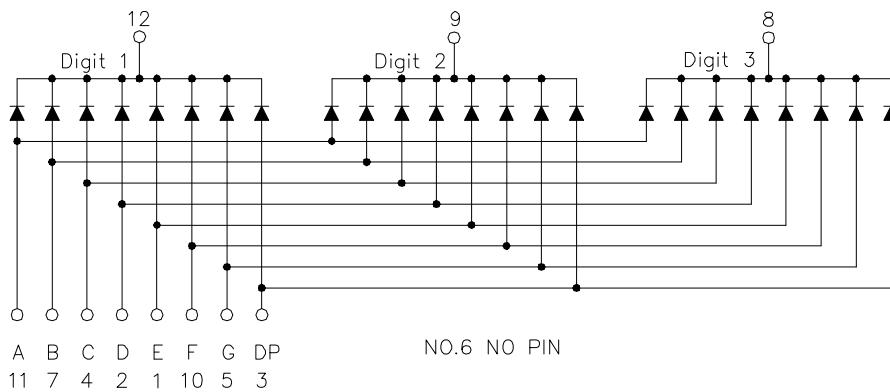

CSDT-36301 is Common Cathode

Model No.: CSDT-36300 CSDT-36301

■ Absolute Maximum Rating -

(Ta=25°C)

Parameter	Symbol	Rating		Unit
		2	M/T/A/V/L/U	
Power Dissipation Per Dice	PAD	114	70	mW
Derating Liner from 25°C per Dice	-	0.4	0.33	mA/°C
Continuous Forward Current Per Dice	IAF	30	25	mA
Peak Current Per Dice(duty cycle 1/10,1KHz)	IPF	100	90	mA
Reverse Voltage Per Dice	VR	5	5	V
Electrostatic discharge(HBM)	ESD	1000	/	V
Operating Temp.	Topr	-35 ~ +85		°C
Storage Temp.	Tstg	-35 ~ +85		°C
Hand Soldering Temp.	Tsol	350		°C

■ Electro-optical Characteristics -

(Ta=25°C)

Parameter	Symbol	Chip	Min.	Typ.	Max.	Unit	Condition
Luminous Intensity Per Segment	Iv	2	-	150	-	mcd	If=10mA
		M	-	8	-		
		T	-	38	-		
		A	-	47	-		
		V	-	23	-		
		L	-	16	-		
		U	-	14	-		
Forward Voltage Per Segment	VF	2	-	3.2	3.8	V	If=20mA
		M/T/A/V/L/U	-	2	2.8		
Peak Emission Wavelength / Dominant Wavelength	λP/λd	2	-	*525	-	nm	If=10mA
		M	-	572/570	-		
		T	-	592/590	-		
		A	-	612/605	-		
		V	-	632/625	-		
		L	-	644/630	-		
		U	-	660/645	-		
Reverse Current	IR		-	-	100	μA	VR=5V
Luminous Intensity Matching Ratio	IV-m		-	-	2:1	-	If=10mA

■ Typical Electrical / Optical Characteristics Curves -  
(Ta = 25°C Unless Otherwise Noted)

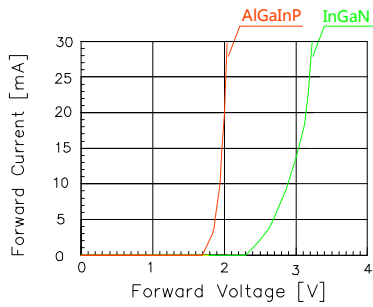

Fig 1. Forward Current vs. Forward Voltage

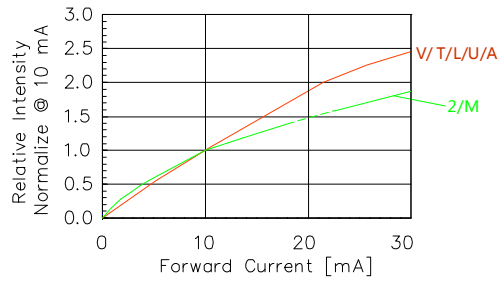

Fig 2. Relative Intensity vs. Forward Current

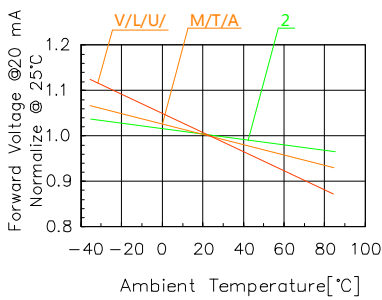

Fig 3. Forward Voltage vs. Temperature

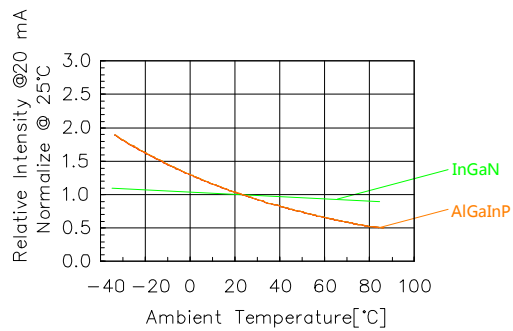

Fig 4. Relative Intensity vs. Temperature

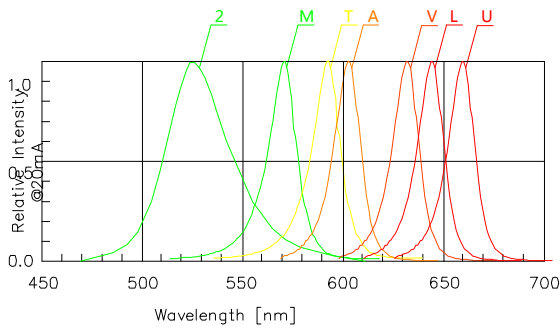

Fig 5. Relative Intensity vs. Wavelength

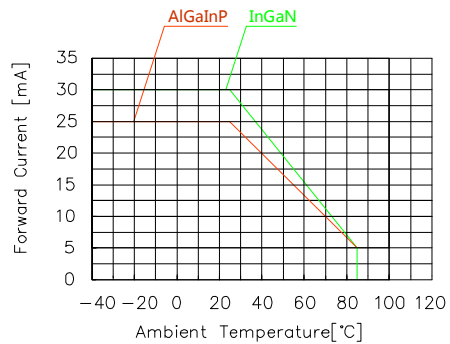

Fig 6. Forward current vs. Temperature

**Model No.: CSDT-36300 CSDT-36301**

**■ Precautions For Use -**

**1.Wave Soldering Profile**

Distance:1.6mm min(From seating plane)

Item	Condition		Note
Preheat	Temperature T1	80 – 120°C	PWB temperature (Soldering side surface)
	Time t1	60 – 180sec	
Solder Dip	Temperature T2	230 – 260°C	Bath temperature
	Time t2	2 – 4sec	Solder tank passage time

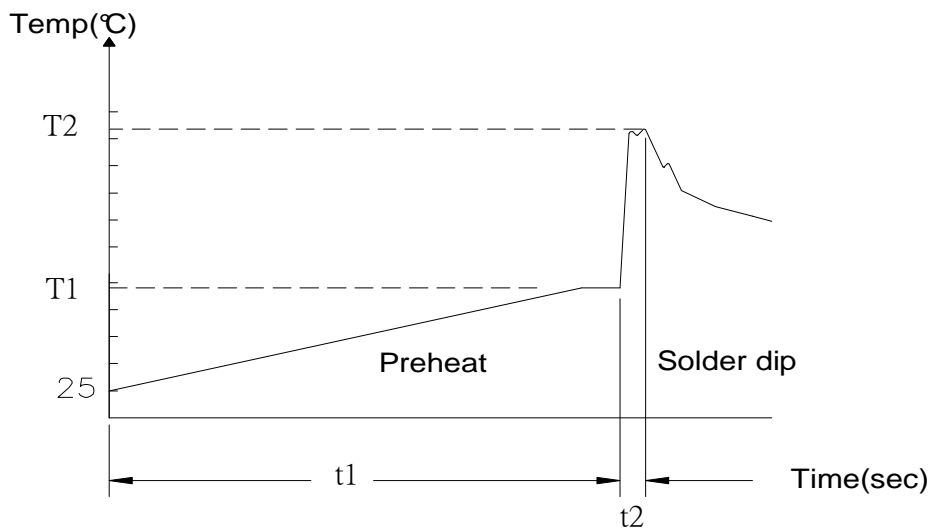

**2.Hand Soldering (Iron Condition)**

Soldering Iron:30W Max

Temperature 350°C Max

Soldering Time:3 Seconds Max(One Time)

Distance:1.6mm min(From seating plane)