

PRODUCT SPECIFICATION

Model No.: CSDT-S56326 CSDT-S56327

Descriptions:
<ul style="list-style-type: none"> ■ 0.56 Inch Triad Digit SMD Display ■ CSDT-S56326 is Common Anode ■ CSDT-S56327 is Common Cathode ■ Emitting Color: Orange , Pure Green,Blue ■ Standard: -11: Gray face, white segment. -21: Black face, white segment.



CUSTOMER APPROVED SIGNATURES	APPROVED BY	CHECKED BY	PREPARED BY

OPTO PLUS TECHNOLOGIES CO.,LTD
 Address:No.696,Yangming North Rd,
 ShaoXing City,ZheJiang Province, P.R.China.
 Tel :86-575-88623888
 Fax:86-575-88623112

Model No.: CSDT-S56326 CSDT-S56327

Features -

1. 0.56 inch (14.2mm) digit height.
2. Qualified according to JEDEC moisture sensitivity Level 2a.
3. RoHS compliant.
4. Low power consumption.
5. Gray face, white segment.
6. Easy mounting on P.C. board .

Device Selection Guide -

Model No.	Chip	
	Material	Emitting Color
CSDT-S5632xV2B	AlGaInP	Orange
	InGaN	Pure Green
	InGaN	Blue

LED Numeric/Alphanumeric Display

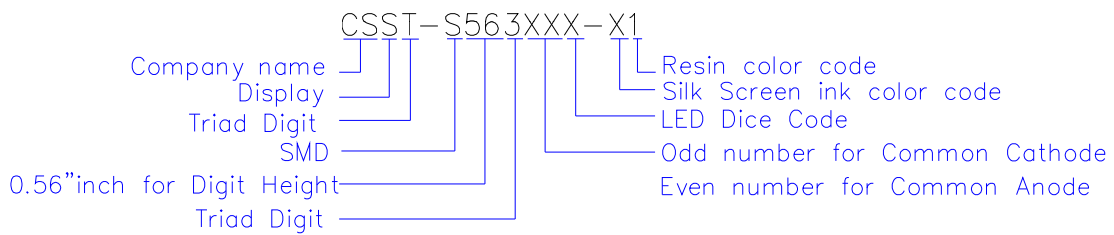

Mechanical Dimensions -

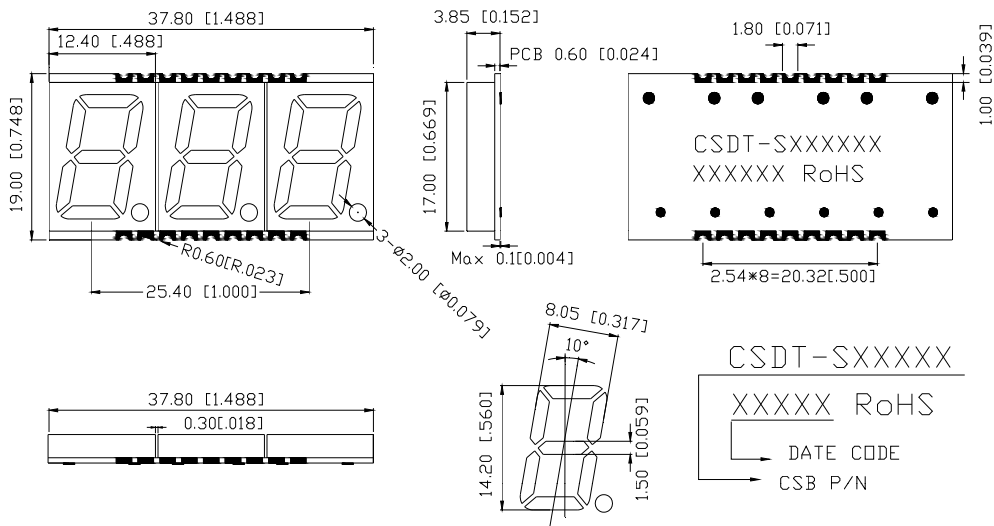

Notes:

1. Dimension in millimeter [inch], and tolerance is ± 0.25 [0.010] unless otherwise noted.
2. Bending \leq Length*1%.

Model No.: CSDT-S56326 CSDT-S56327

■ All Light On Segments Feature & Pad Position

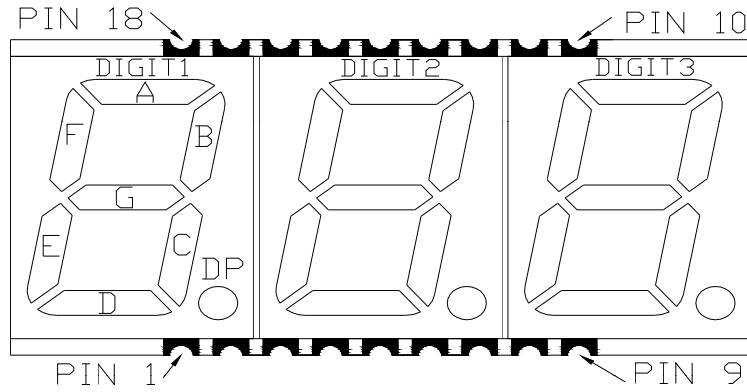

■ Internal Circuit Diagrams -

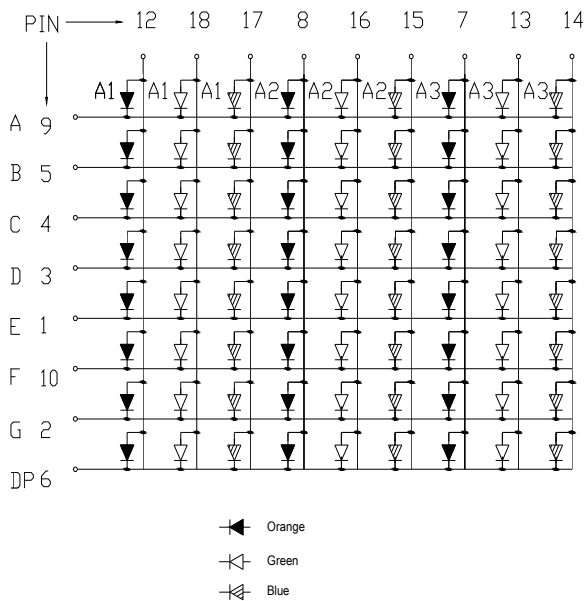

CSDT-S56326 is Common Anode

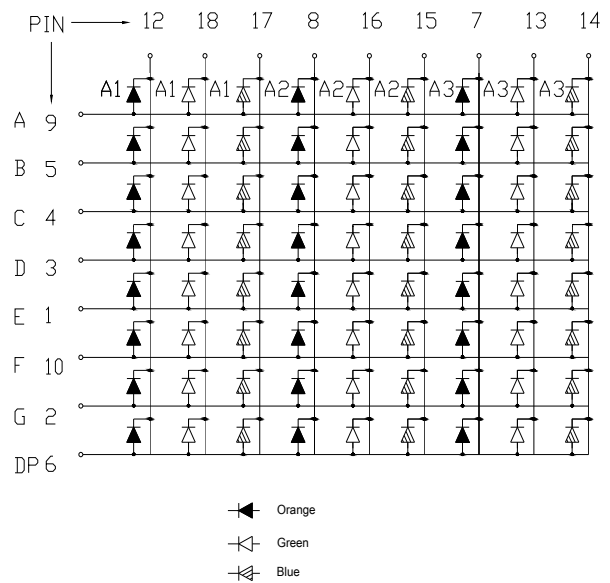

CSDT-S56327 is Common Cathode

Model No.: CSDT-S56326 CSDT-S56327

■ Absolute Maximum Rating -

Orange		(Ta=25°C)	
Parameter	Symbol	Rating	Unit
Power Dissipation Per Dice	P _{AD}	70	mW
Derating Liner from 25°C per Dice	-	0.33	mA/°C
Continuous Forward Current Per Dice	I _{AF}	25	mA
Peak Current Per Dice(duty cycle 1/10,1KHz)	I _{PF}	90	mA
Reverse Voltage Per Dice	VR	5	V
Operating Temp.	T _{opr}	-40 ~ +105	°C
Storage Temp.	T _{stg}	-40 ~ +105	°C
Hand Soldering Temp.	T _{sol}	350	°C

Pure Green		(Ta=25°C)	
Parameter	Symbol	Rating	Unit
Power Dissipation Per Dice	P _{AD}	114	mW
Derating Liner from 25°C per Dice	-	0.4	mA/°C
Continuous Forward Current Per Dice	I _{AF}	30	mA
Peak Current Per Dice(duty cycle 1/10,1KHz)	I _{PF}	100	mA
Reverse Voltage Per Dice	VR	5	V
Electrostatic discharge(HBM)	ESD	1000	V
Operating Temp.	T _{opr}	-40 ~ +105	°C
Storage Temp.	T _{stg}	-40 ~ +105	°C
Hand Soldering Temp.	T _{sol}	350	°C

Blue		(Ta=25°C)	
Parameter	Symbol	Rating	Unit
Power Dissipation Per Dice	P _{AD}	114	mW
Derating Liner from 25°C per Dice	-	0.4	mA/°C
Continuous Forward Current Per Dice	I _{AF}	30	mA
Peak Current Per Dice(duty cycle 1/10,1KHz)	I _{PF}	100	mA
Reverse Voltage Per Dice	VR	5	V
Electrostatic discharge(HBM)	ESD	1000	V
Operating Temp.	T _{opr}	-40 ~ +105	°C
Storage Temp.	T _{stg}	-40 ~ +105	°C
Hand Soldering Temp.	T _{sol}	350	°C

Model No.: CSDT-S56326 CSDT-S56327

■ Electro-optical Characteristics -

Orange							(Ta=25°C)
Parameter	Symbol	Min.	Typ.	Max.	Unit	Condition	
Forward Voltage Per Segment	V _F	-	2	2.8	V	I _F =20mA	
Luminous Intensity Per Segment	I _v	-	8	-	mcd	I _F =10mA	
Peak Emission Wavelength	λ _P	-	632	-	nm	I _F =20mA	
Dominant Wavelength	λ _d	-	625	-	nm	I _F =20mA	
Spectrum Radiation Bandwidth	Δ λ	-	20	-	nm	I _F =20mA	
Reverse Current	I _R	-	-	100	μA	V _R =5V	
Luminous Intensity Matching Ratio	I _{v-m}	-	-	2:1	-	I _F =10mA	

Pure Green							(Ta=25°C)
Parameter	Symbol	Min.	Typ.	Max.	Unit	Condition	
Forward Voltage Per Segment	V _F	-	3.2	3.8	V	I _F =20mA	
Luminous Intensity Per Segment	I _v	-	70	-	mcd	I _F =10mA	
Dominant Wavelength	λ _d	-	525	-	nm	I _F =20mA	
Spectrum Radiation Bandwidth	Δ λ	-	30	-	nm	I _F =20mA	
Reverse Current	I _R	-	-	100	μA	V _R =5V	
Luminous Intensity Matching Ratio	I _{v-m}	-	-	2:1	-	I _F =10mA	

Blue							(Ta=25°C)
Parameter	Symbol	Min.	Typ.	Max.	Unit	Condition	
Forward Voltage Per Segment	V _F	-	3.2	3.8	V	I _F =20mA	
Luminous Intensity Per Segment	I _v	-	12	-	mcd	I _F =10mA	
Dominant Wavelength	λ _d	-	470	-	nm	I _F =20mA	
Spectrum Radiation Bandwidth	Δ λ	-	30	-	nm	I _F =20mA	
Reverse Current	I _R	-	-	100	μA	V _R =5V	
Luminous Intensity Matching Ratio	I _{v-m}	-	-	2:1	-	I _F =10mA	

Note: The device can not operated under continuous reverse voltage.

Model No.: CSDT-S56326 CSDT-S56327

■ Typical Electrical / Optical Characteristics Curves -

● Orange

(Ta = 25°C Unless Otherwise Noted)

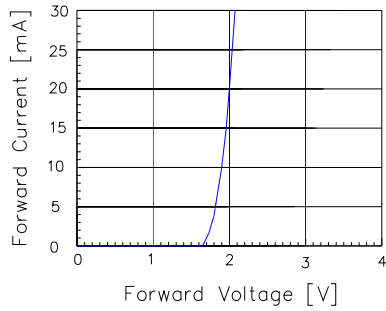

Fig 1. Forward Current vs. Forward Voltage

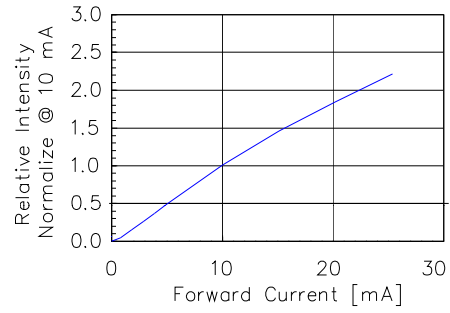

Fig 2. Relative Intensity vs. Forward Current

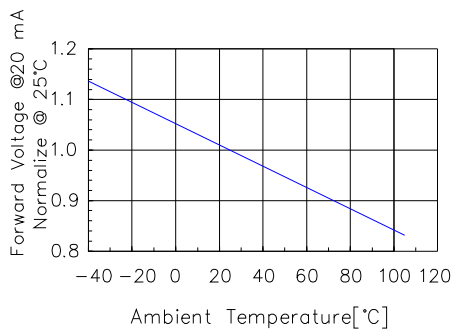

Fig 3. Forward Voltage vs. Temperature

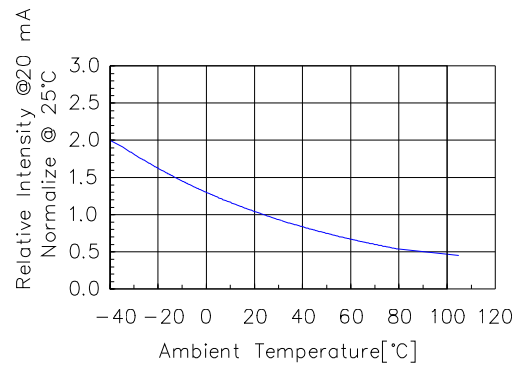

Fig 4. Relative Intensity vs. Temperature

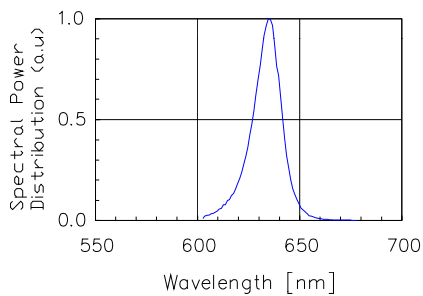

Fig 5. Spectral Power Distribution vs. Wavelength

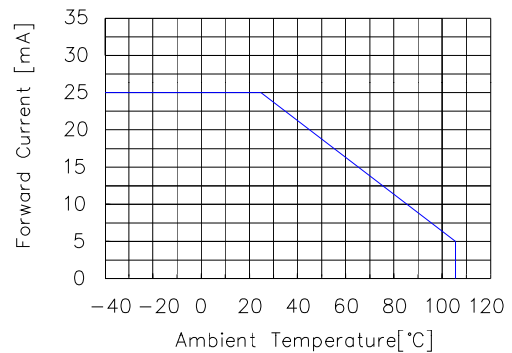

Fig 6. Forward current vs. Temperature

● Pure Green

(Ta = 25°C Unless Otherwise Noted)

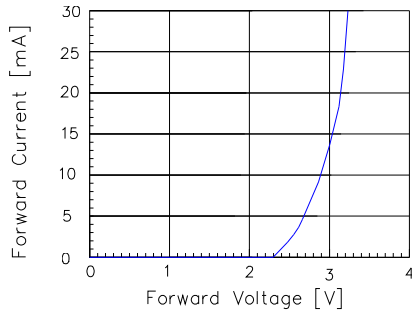

Fig 1. Forward Current vs. Forward Voltage

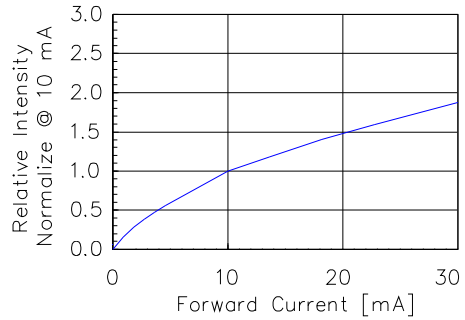

Fig 2. Relative Intensity vs. Forward Current

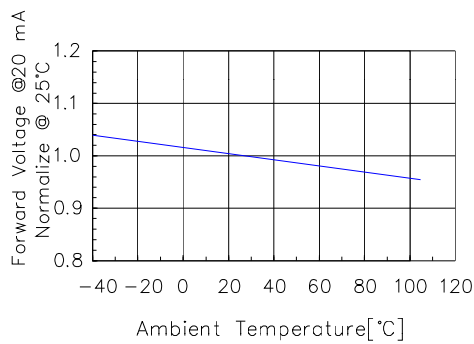

Fig 3. Forward Voltage vs. Temperature

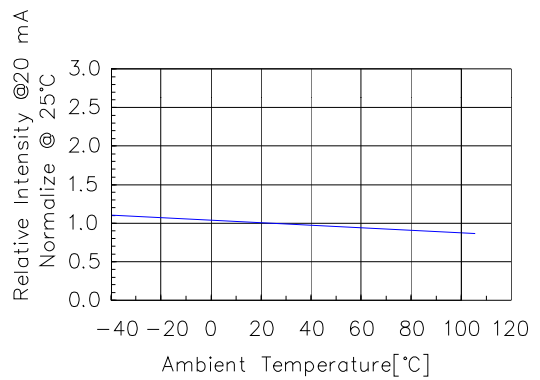

Fig 4. Relative Intensity vs. Temperature

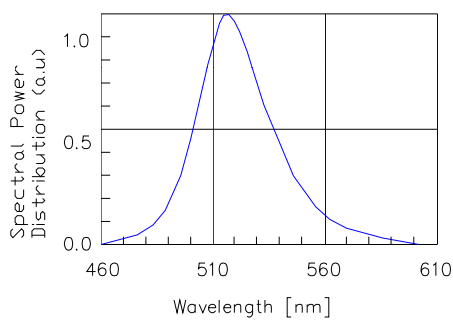

Fig 5. Spectral Power Distribution vs. Wavelength

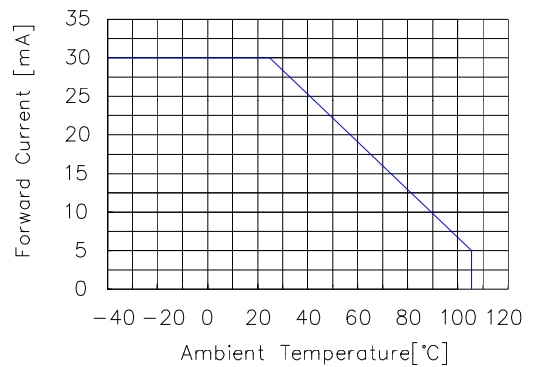

Fig 6. Forward current vs. Temperature

● Blue

(Ta = 25°C Unless Otherwise Noted)

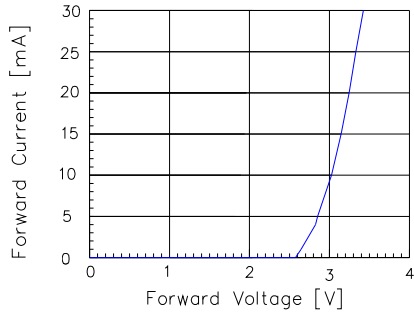

Fig 1. Forward Current vs. Forward Voltage

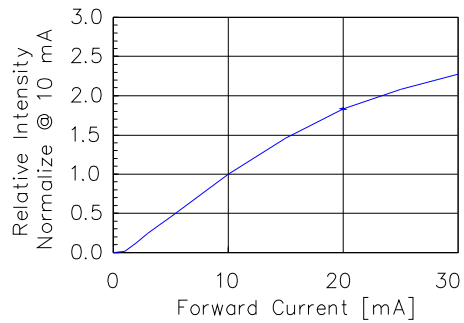

Fig 2. Relative Intensity vs. Forward Current

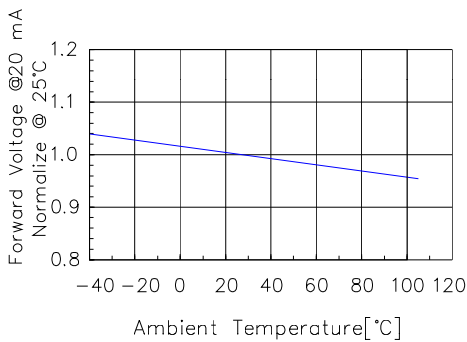

Fig 3. Forward Voltage vs. Temperature

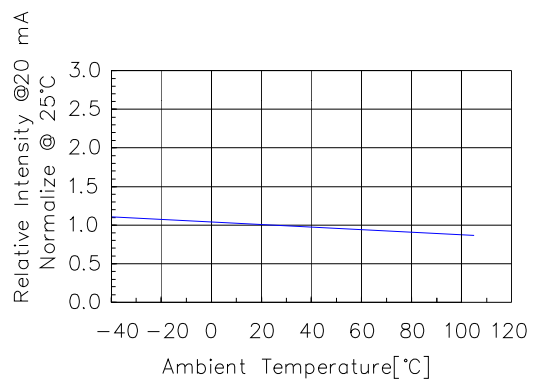

Fig 4. Relative Intensity vs. Temperature

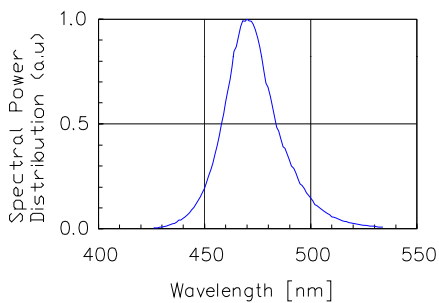

Fig 5. Spectral Power Distribution vs. Wavelength

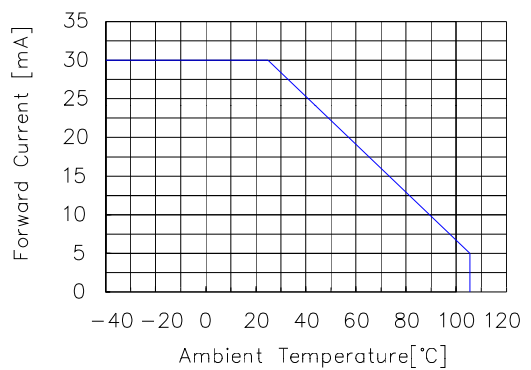
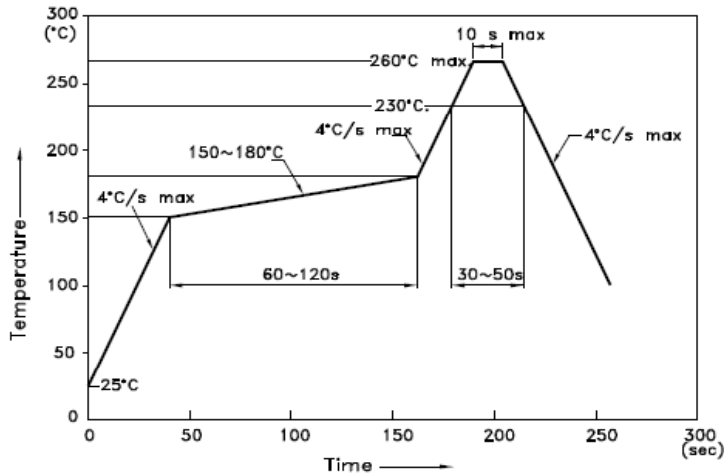

Fig 6. Forward current vs. Temperature

Model No.: CSDT-S56326 CSDT-S56327

IR Reflow Temperature / Time :



NOTES:

1. We recommend the reflow temperature 245°C(+/-5°C). The maximum soldering temperature should be limited to 260°C.
2. Don't cause stress to the epoxy resin while it is exposed to high temperature.
3. Number of reflow process shall be 2 times or less.

Soldering Pad Size

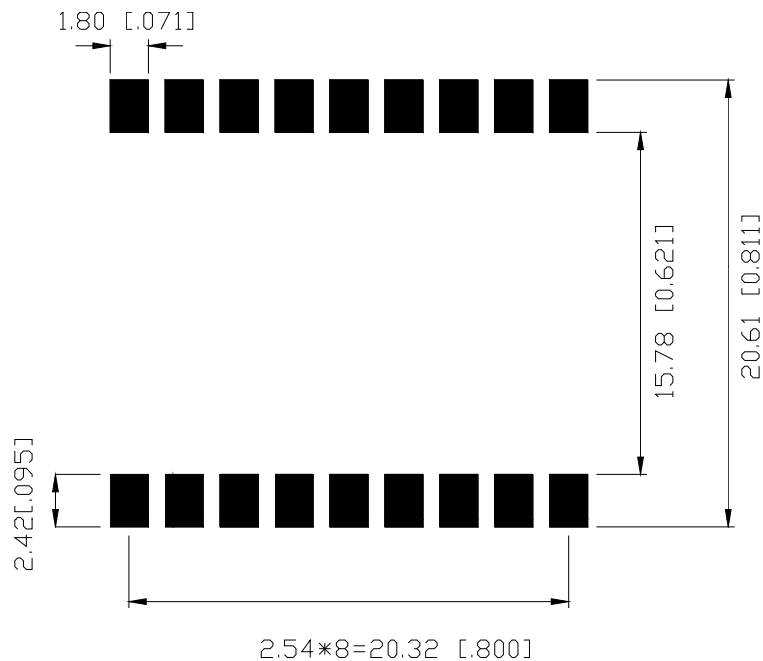

Model No.: CSDT-S56326 CSDT-S56327

REEL DIMENSIONS

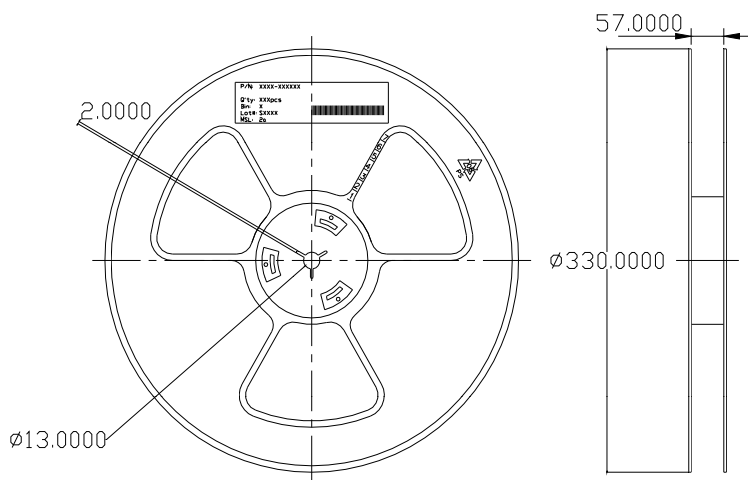

PACKING & LABEL SPECIFICATIONS

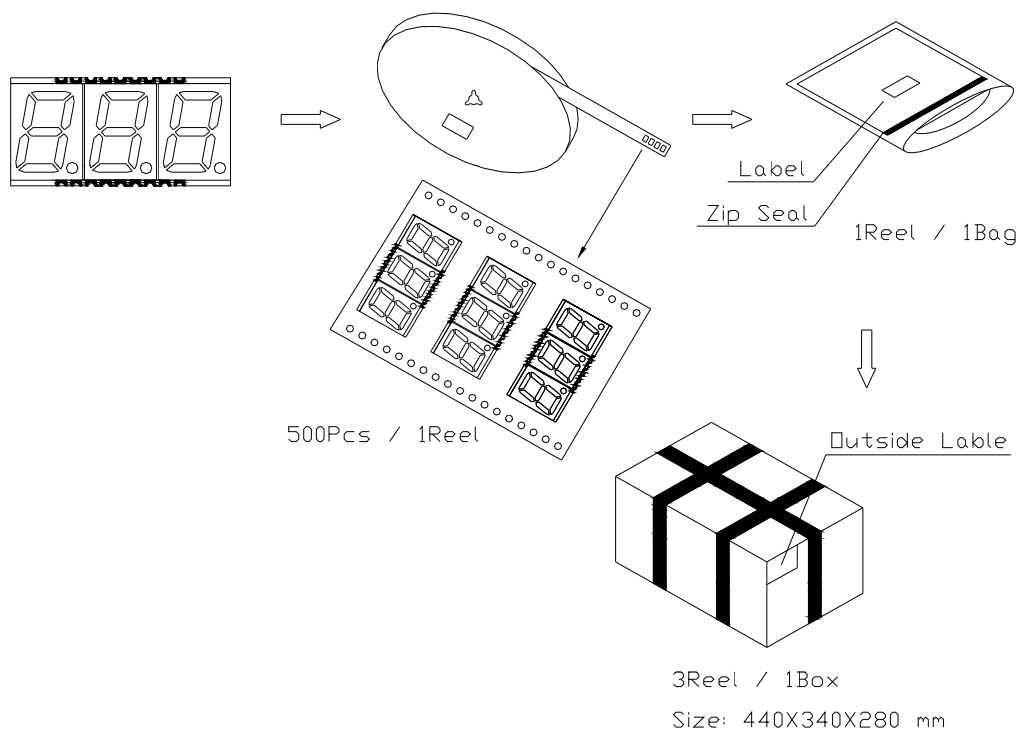

Note: The specifications are subject to change without notice. Please contact us for updated information.