

PRODUCT SPECIFICATION

Model No.: CSDS-40100 CSDS-40101

Descriptions:
<ul style="list-style-type: none"> ■ 0.40 Inch Single Digit Display ■ CSDS-40100 is Common Anode ■ CSDS-40101 is Common Cathode ■ Emitting Color: Pure Green; Yellow Green; Yellow; Amber; Orange; Red; Deep Red ■ Standard: -11: Gray face, white segment. -21: Black face, white segment.



CUSTOMER APPROVED SIGNATURES	APPROVED BY	CHECKED BY	PREPARED BY

OPTO PLUS TECHNOLOGIES CO.,LTD
 Address:No.696,Yangming North Rd,
 ShaoXing City,ZheJiang Province, P.R.China.
 Tel :86-575-88623888
 Fax:86-575-88623112

Model No.: CSDS-40100 CSDS-40101

Features -

1. 0.40 inch (10.16mm) digit height.
2. Case mold type.
3. RoHS compliant.
4. Low power consumption.
5. Easy mounting on P.C. board or socket.

Device Selection Guide -

Model No.	Chip	
	Material	Emitting Color
CSDS-4010x2	InGaN	Pure Green
CSDS-4010xM	AlGaInP	Yellow Green
CSDS-4010xT		Yellow
CSDS-4010xA		Amber
CSDS-4010xV		Orange
CSDS-4010xL		Red
CSDS-4010xU		Deep Red

LED Numeric/Alphanumeric Display

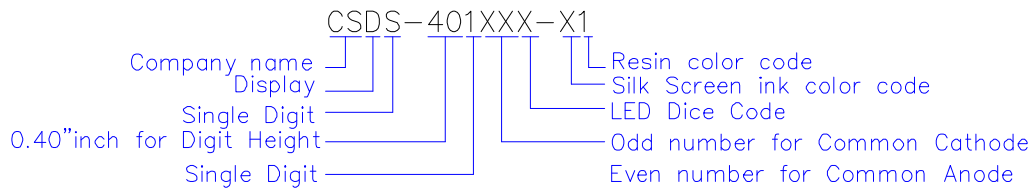

Mechanical Dimensions -

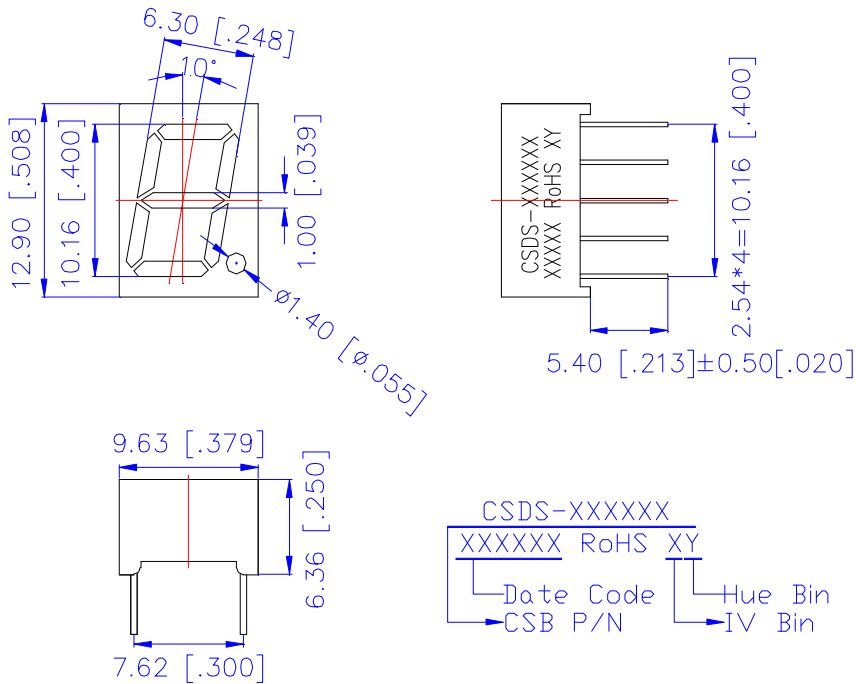

Notes:

1. All pins are $\varnothing 0.45[.018] \pm 0.1[.004]$
2. Dimension in millimeter [inch], tolerance is $\pm 0.25[.010]$ and angle is $\pm 1^\circ$ unless otherwise noted.
3. Bending \leq Length*1%.

Model No.: CSDS-40100 CSDS-40101

■ All Light On Segments Feature & Pin Position

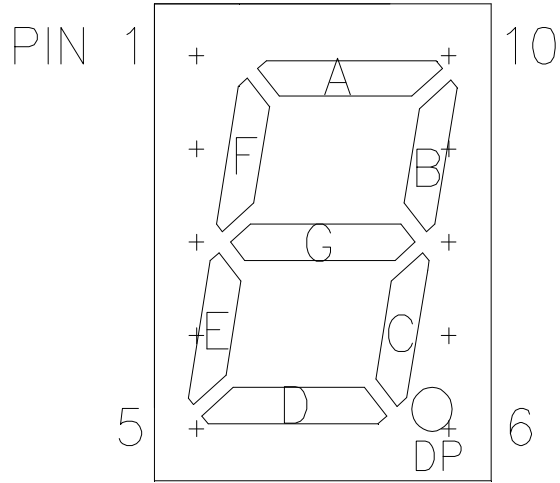

■ Internal Circuit Diagrams -

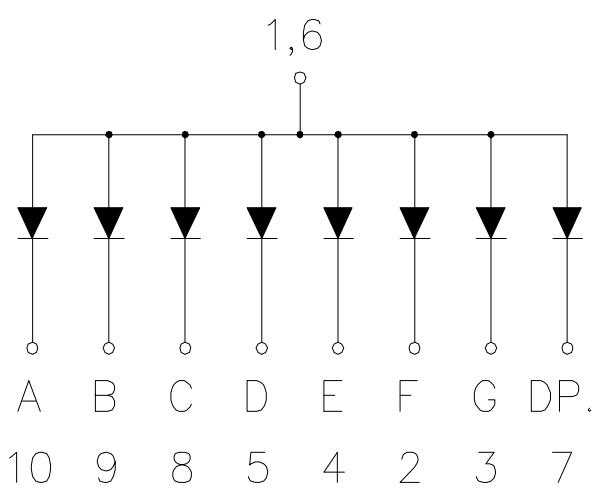

CSDS-40100 is Common Anode

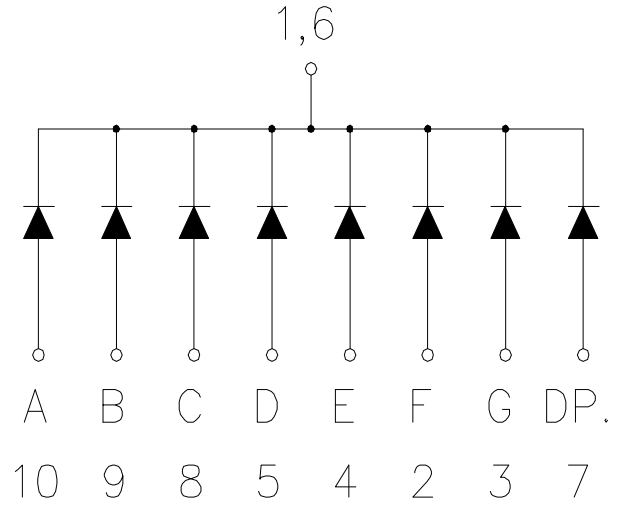

CSDS-40101 is Common Cathode

Model No.: CSDS-40100 CSDS-40101

■ Absolute Maximum Rating -

(Ta=25°C)

Parameter	Symbol	Rating		Unit
		M / T / A / V / L / U	2	
Power Dissipation Per Dice	PAD	70	114	mW
Derating Liner from 25°C per Dice	-	0.33	0.4	mA/°C
Continuous Forward Current Per Dice	IAF	25	30	mA
Peak Current Per Dice(duty cycle 1/10,1KHz)	IPF	90	100	mA
Reverse Voltage Per Dice	VR	5	5	V
Electrostatic discharge(HBM)	ESD	/	1000	V
Operating Temp.	Topr	-35 ~ +85		°C
Storage Temp.	Tstg	-35 ~ +85		°C
Hand Soldering Temp.	Tsol	350		°C

■ Electro-optical Characteristics -

(Ta=25°C)

Parameter	Symbol	Chip	Min.	Typ.	Max.	Unit	Condition
Luminous Intensity Per Segment	Iv	2	-	150	-	mcd	If=10mA
		M	-	15	-		
		T	-	40	-		
		A	-	50	-		
		V	-	28	-		
		L	-	24	-		
		U	-	20	-		
Forward Voltage Per Segment	VF	2	-	3.2	3.8	V	If=20mA
		M/T/A/V/L/U	-	2	2.8		
Peak Emission Wavelength / Dominant Wavelength	λP/λd	2	-	*1525	-	nm	If=20mA
		M	-	572/570	-		
		T	-	592/590	-		
		A	-	612/605	-		
		V	-	632/625	-		
		L	-	644/630	-		
		U	-	660/645	-		
Reverse Current	IR		-	-	100	μA	VR=5V
Luminous Intensity Matching Ratio	IV-m		-	-	2:1	-	If=10mA

■ Typical Electrical / Optical Characteristics Curves -

(Ta = 25°C Unless Otherwise Noted)

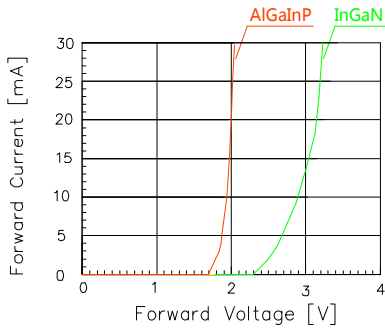

Fig 1. Forward Current vs. Forward Voltage

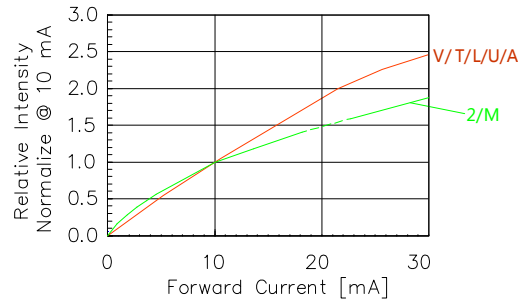

Fig 2. Relative Intensity vs. Forward Current

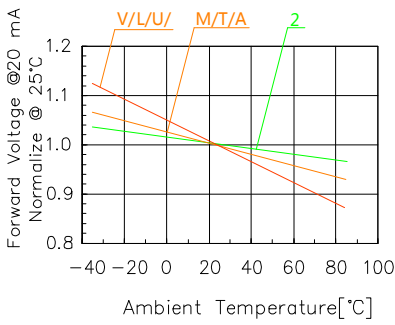

Fig 3. Forward Voltage vs. Temperature

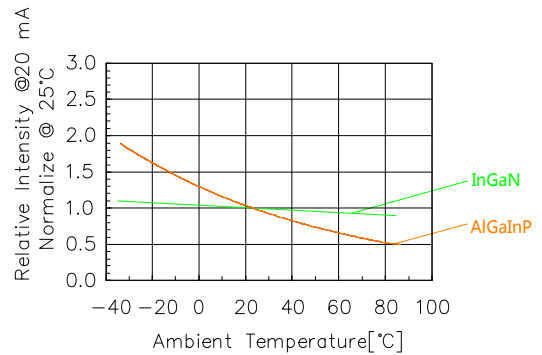

Fig 4. Relative Intensity vs. Temperature

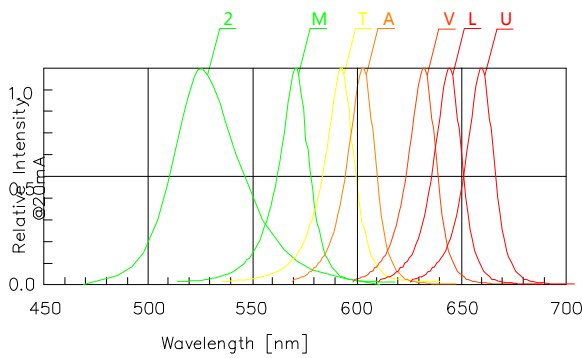

Fig 5. Relative Intensity vs. Wavelength

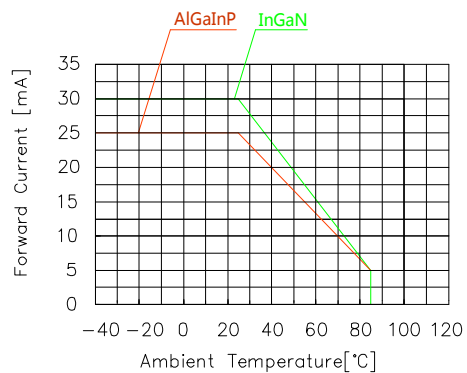

Fig 6. Forward current vs. Temperature

Model No.: CSDS-40100 CSDS-40101

■ Precautions For Use -

1.Wave Soldering Profile

Distance:1.6mm min(From seating plane)

Item	Condition		Note
Preheat	Temperature T1	80 – 120°C	PWB temperature (Soldering side surface)
	Time t1	60 – 180sec	
Solder Dip	Temperature T2	230 – 260°C	Bath temperature
	Time t2	2 – 4sec	Solder tank passage time

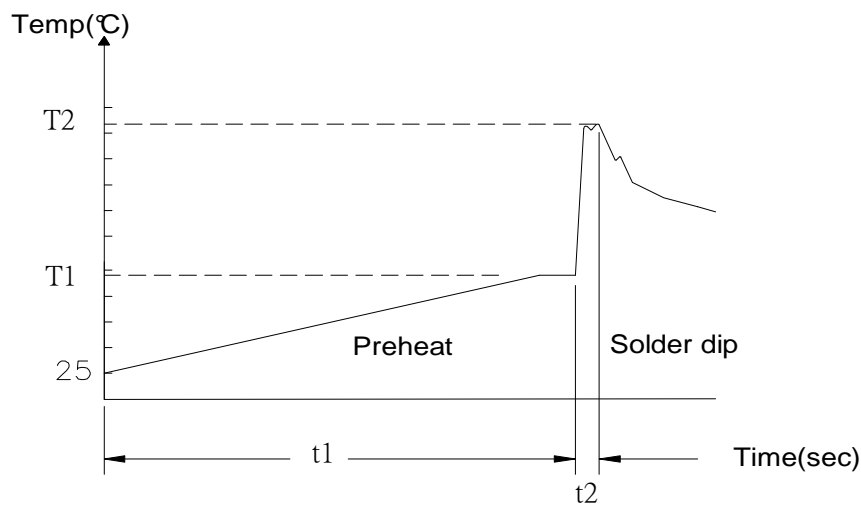

2.Hand Soldering (Iron Condition)

Soldering Iron:30W Max

Temperature 350°C Max

Soldering Time:3 Seconds Max(One Time)

Distance:1.6mm min(From seating plane)