

PRODUCT SPECIFICATION

Model No.: CSDS-1A102 CSDS-1A103

Descriptions:
<ul style="list-style-type: none"> ■ 1.0 Inch Single Digit Display ■ CSDS-1A102 is Common Anode ■ CSDS-1A103 is Common Cathode ■ Emitting Color: Pure Green; Yellow Green; Yellow; Amber; Orange; Red; Deep Red ■ Standard: -11: Gray face, white segment. -21: Black face, white segment.



CUSTOMER APPROVED SIGNATURES	APPROVED BY	CHECKED BY	PREPARED BY

OPTO PLUS TECHNOLOGIES CO.,LTD
 Address: No.696, Yangming North Rd,
 ShaoXing City, ZheJiang Province, P.R.China.
 Tel : 86-575-88623888
 Fax: 86-575-88623112

Model No.: CSDS-1A102 CSDS-1A103

Features -

1. 1.0 inch (25.40mm) digit height.
2. Case mold type.
3. RoHS compliant.
4. Low power consumption.
5. Easy mounting on P.C. board or socket.

Device Selection Guide -

Model No.	Chip	
	Material	Emitting Color
CSDS-1A10x2	InGaN	Pure Green
CSDS-1A10xM	AlGaInP	Yellow Green
CSDS-1A10xT		Yellow
CSDS-1A10xA		Amber
CSDS-1A10xV		Orange
CSDS-1A10xL		Red
CSDS-1A10xU		Deep Red

LED Numeric/Alphanumeric Display

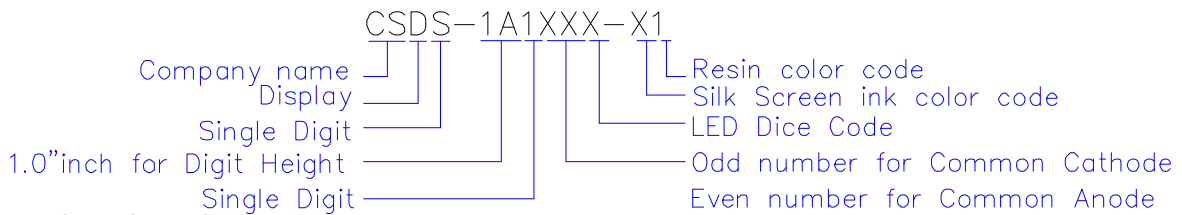

Mechanical Dimensions -

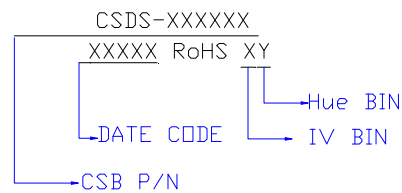
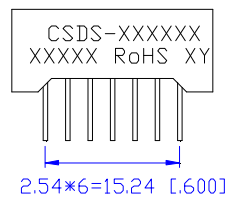
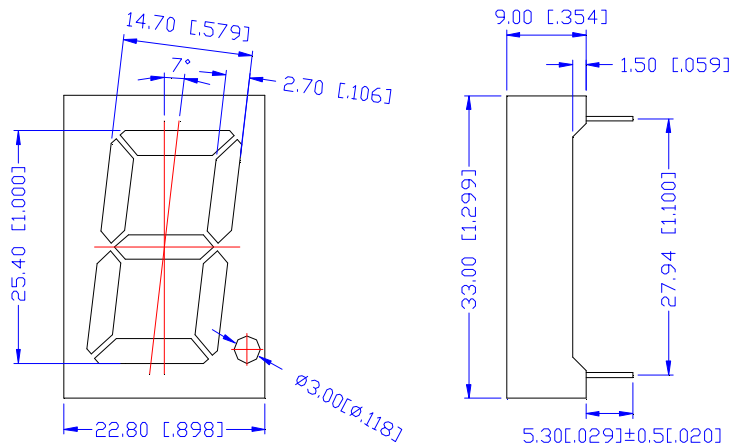

Notes:

1. All pins are $\varnothing 0.51 [0.020] \pm 0.1 [0.004]$
2. Dimension in millimeter [inch], tolerance is $\pm 0.25 [0.010]$ and angle is $\pm 1^\circ$ unless otherwise noted.
3. Bending \leq Length*1%.

Model No.: CSDS-1A102 CSDS-1A103

■ All Light On Segments Feature & Pin Position

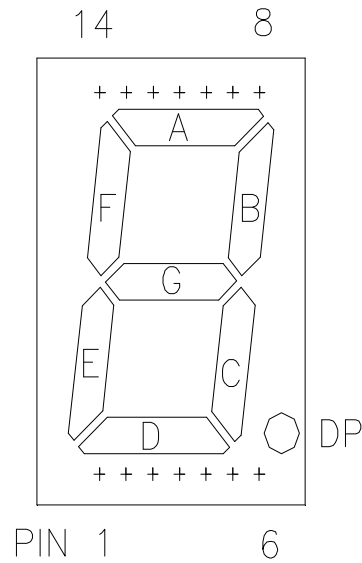

■ Internal Circuit Diagrams -

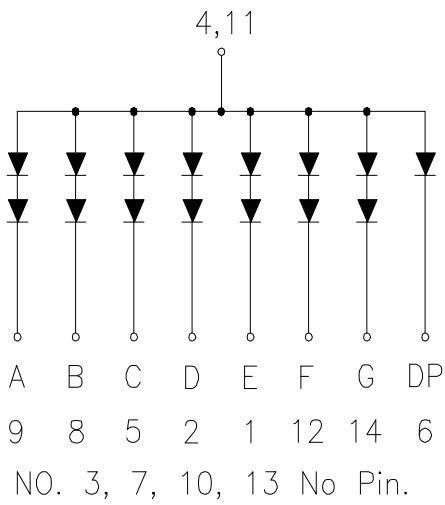

CSDS-1A102 is Common Anode

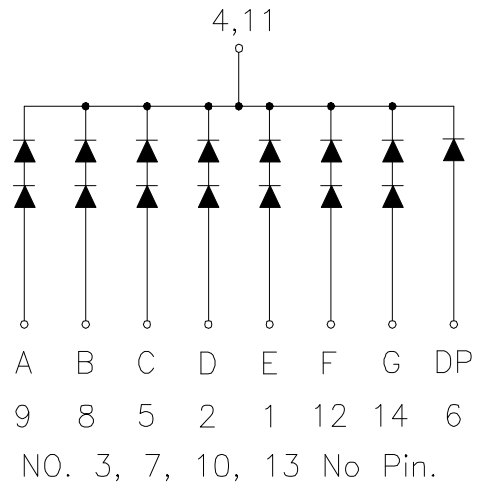

CSDS-1A103 is Common Cathode

Model No.: CSDS-1A102 CSDS-1A103

■ Absolute Maximum Rating -

(Ta=25°C)

Parameter	Symbol	Rating		Unit
		2	M/T/A/V/L/U	
Power Dissipation Per Dice	PAD	114	70	mW
Derating Liner from 25°C per Dice	-	0.4	0.33	mA/°C
Continuous Forward Current Per Dice	IAF	30	25	mA
Peak Current Per Dice(duty cycle 1/10,1KHz)	IPF	100	90	mA
Reverse Voltage Per Dice	VR	5	5	V
Electrostatic discharge(HBM)	ESD	1000	/	V
Operating Temp.	Topr	-35 ~ +85		°C
Storage Temp.	Tstg	-35 ~ +85		°C
Hand Soldering Temp.	Tsol	350		°C

■ Electro-optical Characteristics -

(Ta=25°C)

Parameter	Symbol	Chip	Min.	Typ.	Max.	Unit	Condition
Luminous Intensity Per Segment	Iv	2	-	576	-	mcd	If=10mA
		M	-	32	-		
		T	-	137	-		
		A	-	181	-		
		V	-	88	-		
		L	-	60	-		
		U	-	46	-		
Forward Voltage Per Segment(DP)	VF	2	-	6.4(3.2)	7.6(3.8)	V	If=20mA
		M/T/A/V/L/U	-	4(2)	5.6(2.8)		
Peak Emission Wavelength / Dominant Wavelength	λP/λd	2	-	*525	-	nm	If=20mA
		M	-	572/570	-		
		T	-	592/590	-		
		A	-	612/605	-		
		V	-	632/625	-		
		L	-	644/630	-		
Reverse Current	IR		-	-	100	μA	VR=10(5)V
Luminous Intensity Matching Ratio	IV-m		-	-	2:1	-	If=10mA

■ Typical Electrical / Optical Characteristics Curves -

(Ta = 25°C Unless Otherwise Noted)

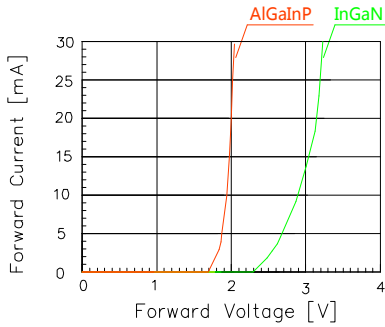

Fig 1. Forward Current vs. Forward Voltage

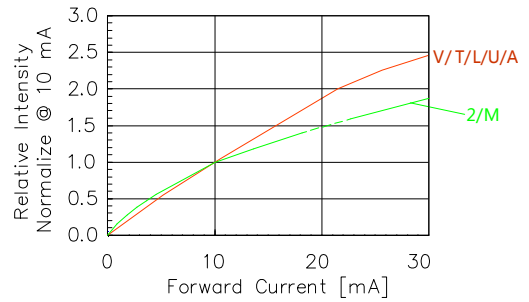

Fig 2. Relative Intensity vs. Forward Current

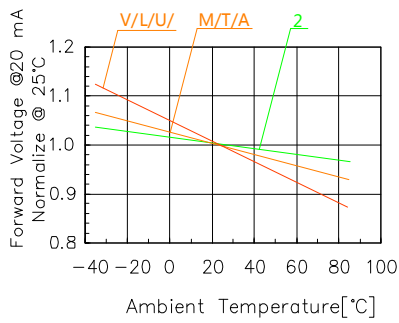

Fig 3. Forward Voltage vs. Temperature

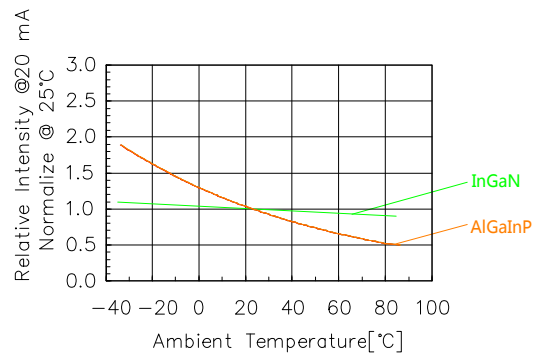

Fig 4. Relative Intensity vs. Temperature

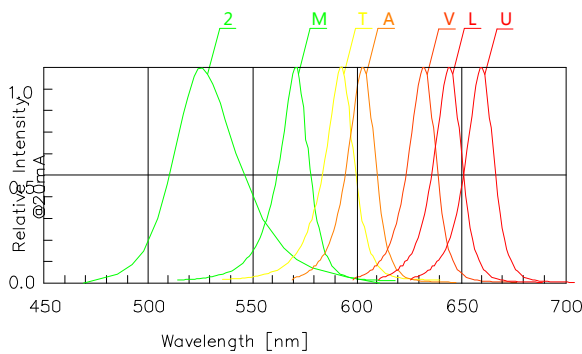

Fig 5. Relative Intensity vs. Wavelength

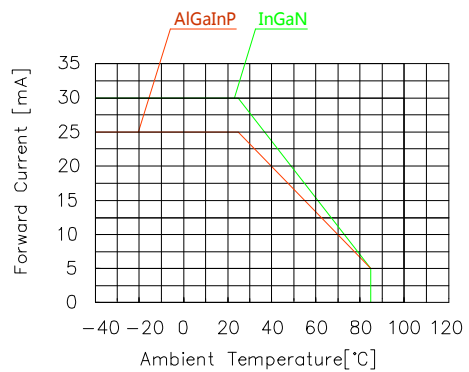

Fig 6. Forward current vs. Temperature

Model No.: CSDS-1A102 CSDS-1A103

■ Precautions For Use -

1.Wave Soldering Profile

Distance:1.6mm min(From seating plane)

Item	Condition		Note
Preheat	Temperature T1	80 – 120°C	PWB temperature (Soldering side surface)
	Time t1	60 – 180sec	
Solder Dip	Temperature T2	230 – 260°C	Bath temperature
	Time t2	2 – 4sec	Solder tank passage time

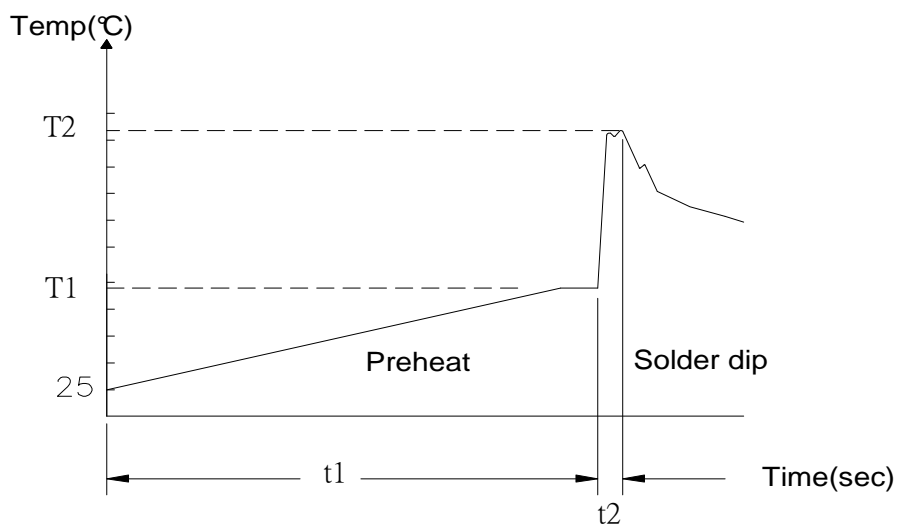

2.Hand Soldering (Iron Condition)

Soldering Iron:30W Max

Temperature 350°C Max

Soldering Time:3 Seconds Max(One Time)

Distance:1.6mm min(From seating plane)