

PRODUCT SPECIFICATION

Model No.: CSDT-S30320 CSDT-S30321

Descriptions:
<ul style="list-style-type: none"> ■ 0.30 Inch Triple Digit SMD Display ■ CSDT-S30320 is Common Anode ■ CSDT-S30321 is Common Cathode ■ Emitting Color: Pure Green; Yellow Green; Yellow; Amber; Orange; Red; Deep Red ■ Standard: -11: Gray face, white segment. -21: Black face, white segment.



CUSTOMER APPROVED SIGNATURES	APPROVED BY	CHECKED BY	PREPARED BY

OPTO PLUS TECHNOLOGIES CO.,LTD
 Address:No.696,Yangming North Rd,
 ShaoXing City,ZheJiang Province, P.R.China.
 Tel :86-575-88623888
 Fax:86-575-88623112

Model No.: CSDT-S30320 CSDT-S30321

■ **Features -**

1. 0.30 inch (7.62mm) digit height
2. Qualified according to JEDEC moisture sensitivity Level 2a.
3. RoHS compliant.
4. Low power consumption.
5. Easy mounting on P.C. board .

■ **Device Selection Guide -**

Model No.	Chip	
	Material	Emitting Color
CSDT-S3032x2	InGaN	Pure Green
CSDT-S3032xM	AlGaInP	Yellow Green
CSDT-S3032xT		Yellow
CSDT-S3032xA		Amber
CSDT-S3032xV		Orange
CSDT-S3032xL		Red
CSDT-S3032xU		Deep Red

■ **LED Numeric/Alphanumeric Display**

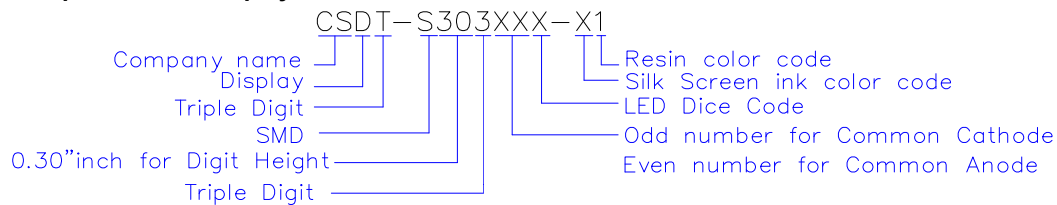

■ **Mechanical Dimensions -**

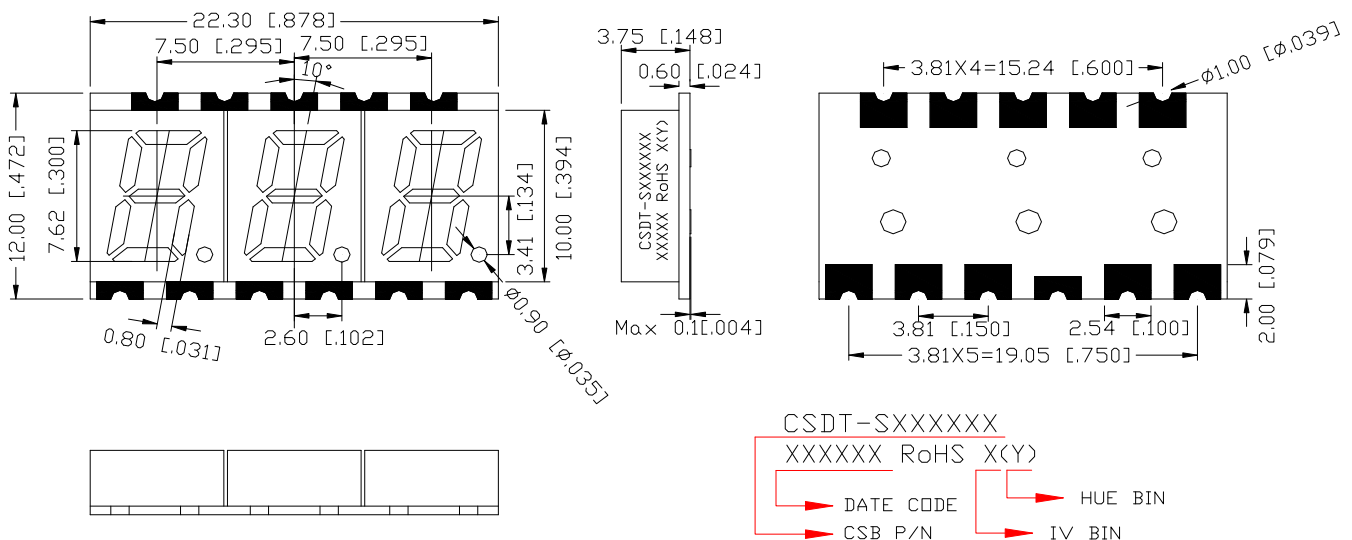

Notes:

1. Dimension in millimeter [inch], tolerance is ± 0.25 [0.010] and angle is $\pm 1^\circ$ unless otherwise noted.
2. Bending \leq Length*1%.

Model No.: CSDT-S30320 CSDT-S30321

■ All Light On Segments Feature & Pin Position

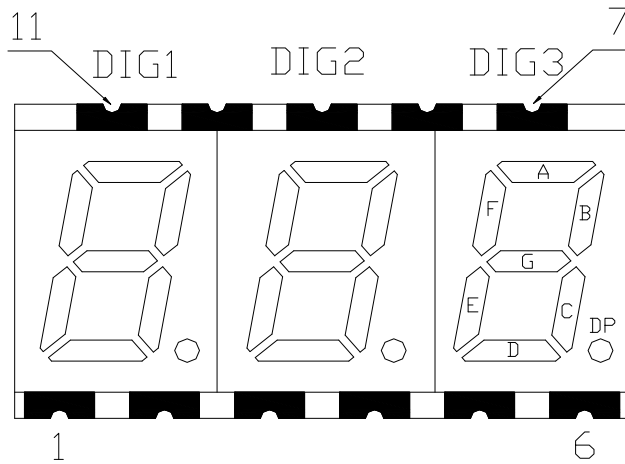

■ Internal Circuit Diagrams -

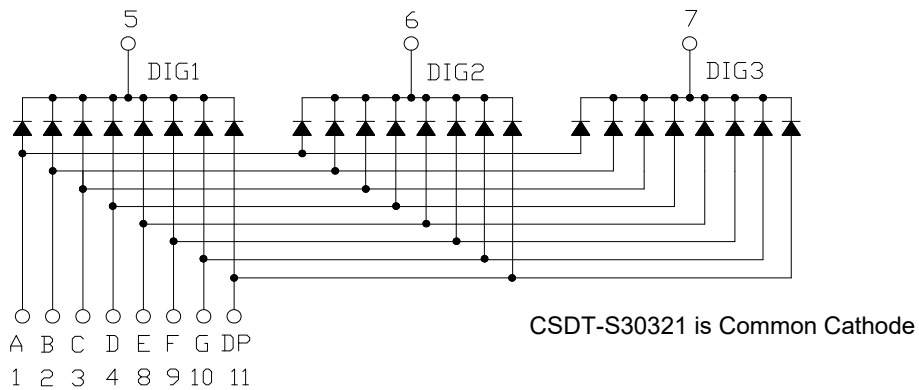
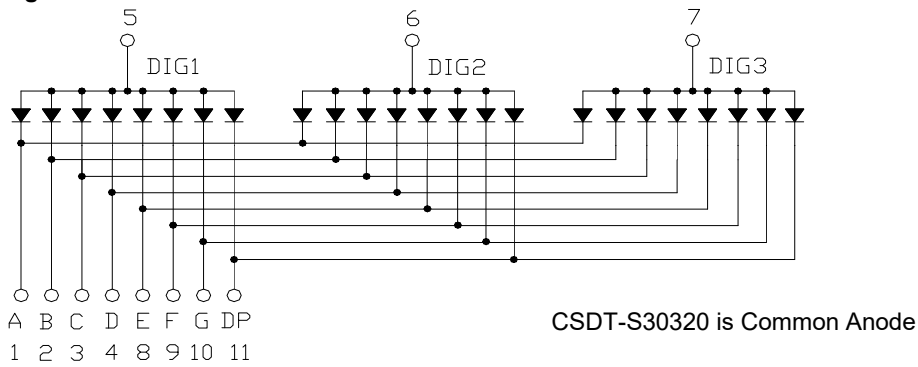

Model No.: CSDT-S30320 CSDT-S30321

■ Absolute Maximum Rating -

(Ta=25°C)

Parameter	Symbol	Rating		Unit
		2	M / T / A / V / L / U	
Power Dissipation Per Dice	PAD	114	70	mW
Derating Liner from 25°C per Dice	-	0.4	0.33	mA/°C
Continuous Forward Current Per Dice	IAF	30	25	mA
Peak Current Per Dice(duty cycle 1/10,1KHz)	IPF	100	90	mA
Reverse Voltage Per Dice	VR	5	5	V
Electrostatic discharge(HBM)	ESD	1000	/	V
Operating Temp.	Topr	-40 ~ +105		°C
Storage Temp.	Tstg	-40 ~ +105		°C
Hand Soldering Temp.	Tsol	350		°C

■ Electro-optical Characteristics -

(Ta=25°C)

Parameter	Symbol	Chip	Min.	Typ.	Max.	Unit	Condition
Luminous Intensity Per Segment	Iv	2	-	70	-	mcd	If=10mA
		M	-	2	-		
		T	-	8	-		
		A	-	9	-		
		V	-	5	-		
		L	-	4	-		
		U	-	2	-		
Forward Voltage Per Segment	VF	2	-	3.2	3.8	V	If=20mA
		M/T/A/V/L/U	-	2	2.8		
Peak Emission Wavelength / Dominant Wavelength	λP/λd	2	-	*/525	-	nm	If=10mA
		M	-	572/570	-		
		T	-	592/590	-		
		A	-	612/605	-		
		V	-	632/625	-		
		L	-	644/630	-		
		U	-	660/645	-		
Reverse Current	IR		-	-	100	μA	VR=5V
Luminous Intensity Matching Ratio	IV-m		-	-	2:1	-	If=10mA

■ Electrical / Optical Characteristics Curves -

(Ta = 25°C Unless Otherwise Noted)

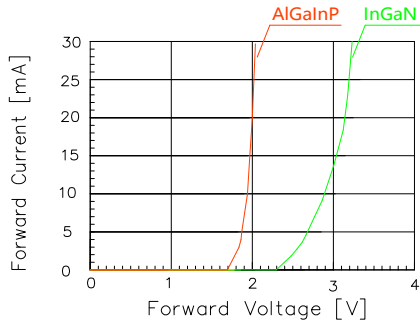

Fig 1. Forward Current vs. Forward Voltage

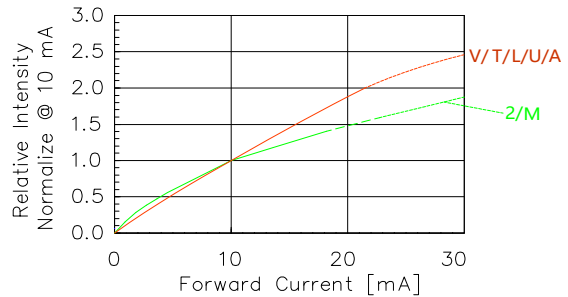

Fig 2. Relative Intensity vs. Forward Current

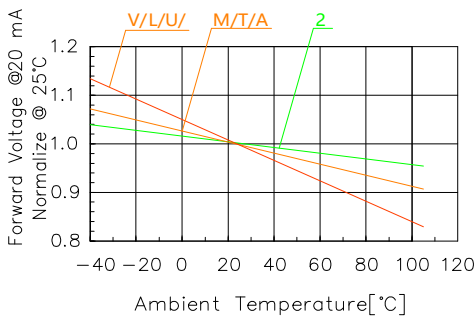

Fig 3. Forward Voltage vs. Temperature

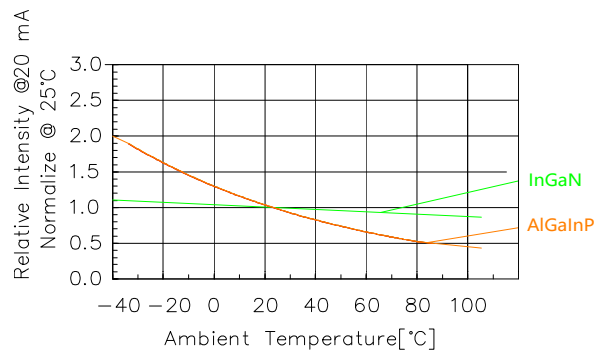

Fig 4. Relative Intensity vs. Temperature

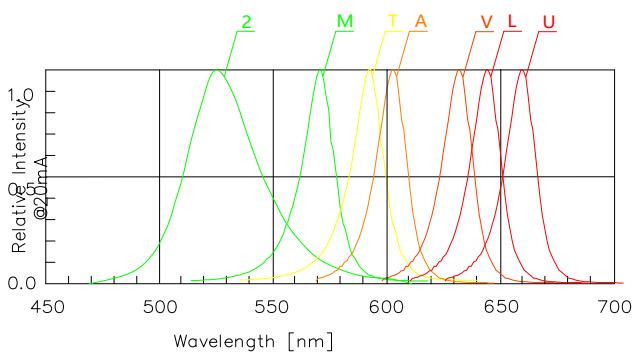

Fig 5. Relative Intensity vs. Wavelength

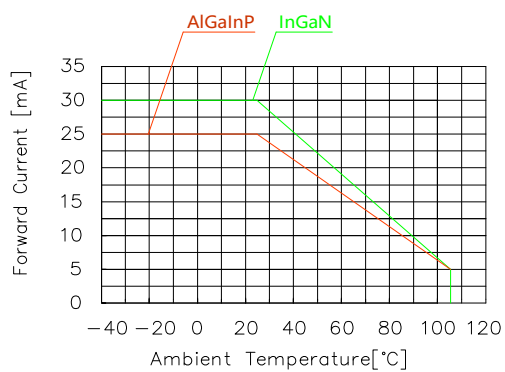
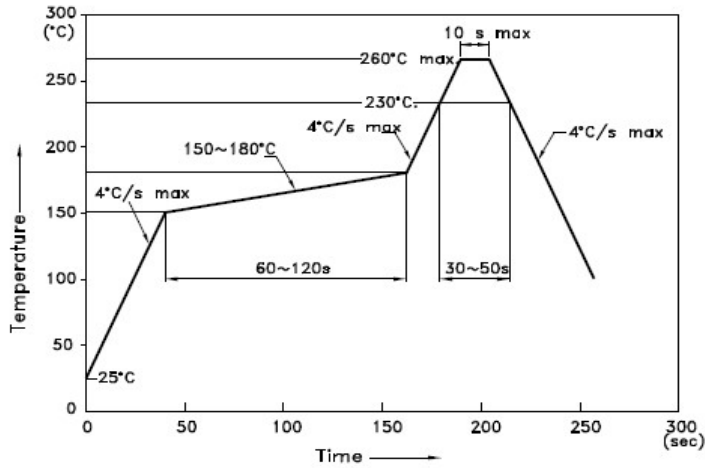

Fig 6. Forward current vs. Temperature

Model No.: CSDT-S30320 CSDT-S30321

SMT REFLOW SOLDERING INSTRUCTIONS

■ IR Reflow Temperature / Time :



NOTES:

1. We recommend the reflow temperature 245°C(+/-5°C). The maximum soldering temperature should be limited to 260°C.
2. Don't cause stress to the epoxy resin while it is exposed to high temperature.
3. Number of reflow process shall be 2 times or less.

■ Soldering Pad Size

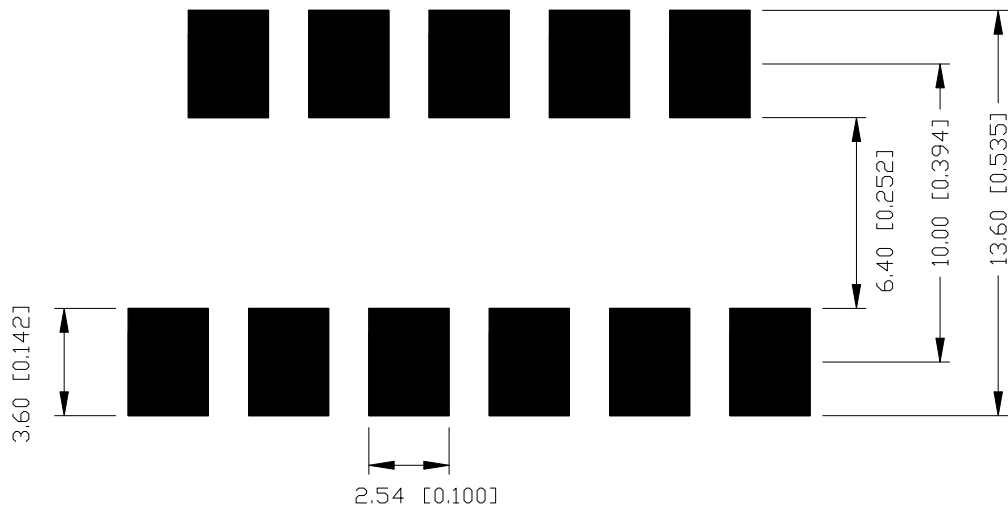

Model No.: CSDT-S30320 CSDT-S30321

REEL DIMENSIONS

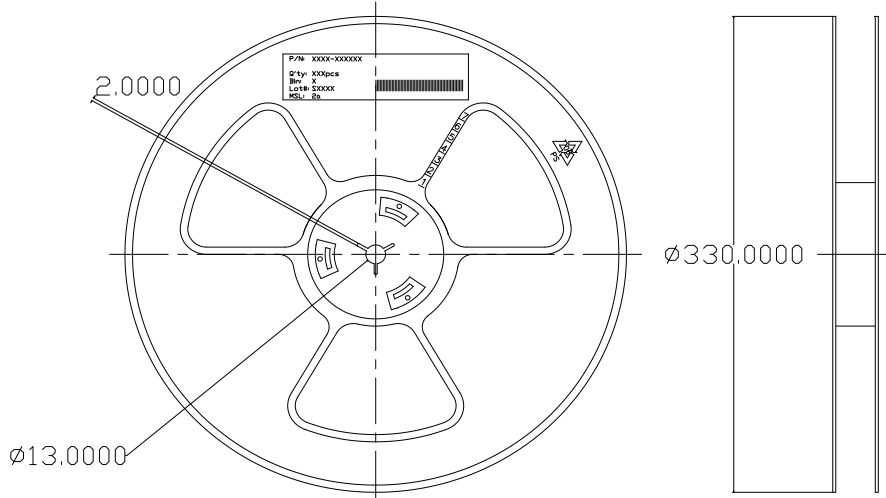

PACKING & LABEL SPECIFICATIONS

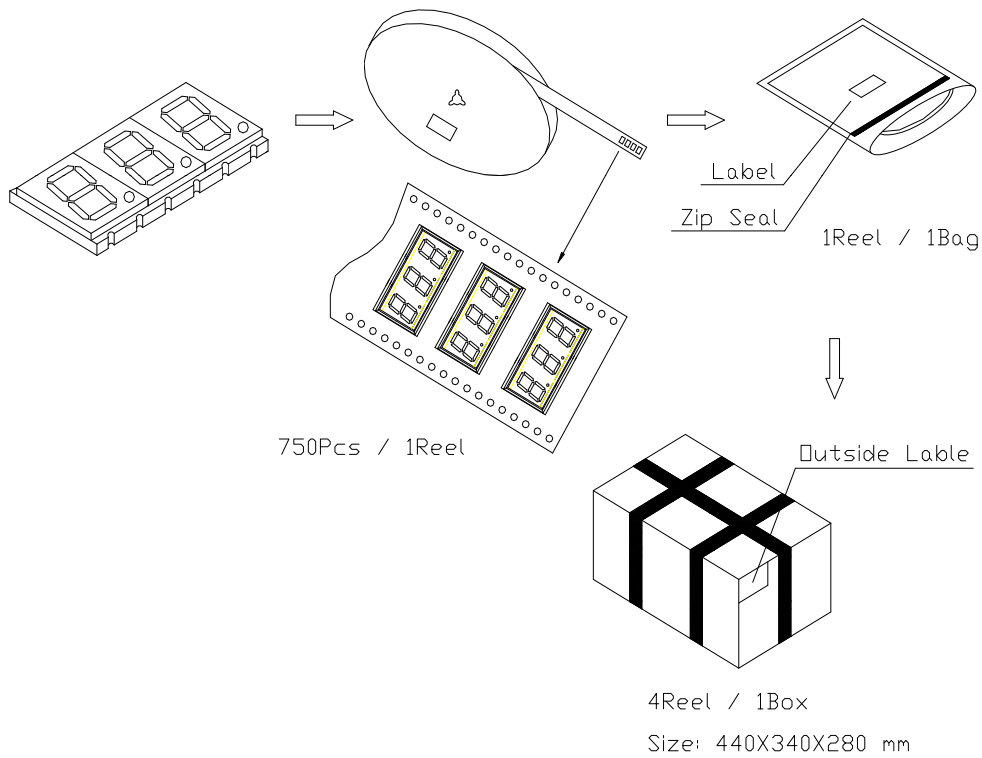

Note: The specifications are subject to change without notice. Please contact us for updated information.